

Booster BMD-10 v5

- VERSION 4 A
- VERSION 6 A
- VERSION 8 A

Fifth Generation

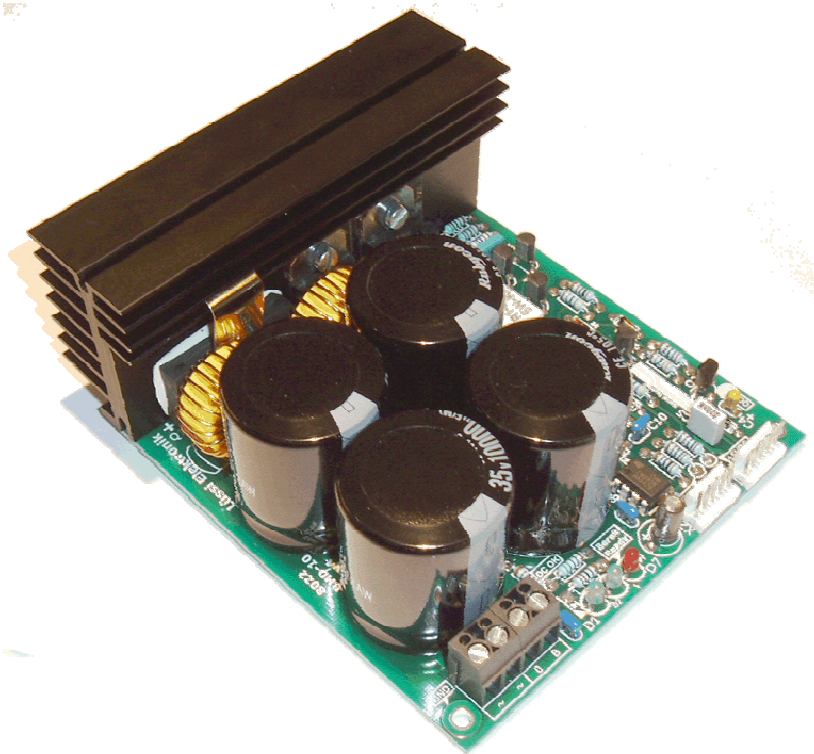

INTRODUCTION

The booster is suitable for the employment with model railway facilities of the gauges Z, N, TT, H0, 0, 1 up to G. It processes both the Märklin[®]* Motorola[®]* as well as DCC format. When using a multi-protocol capable central unit a mixed MM/DCC is possible.

The booster is available in three versions, which electrically differ only by the maximum traction current of 4 A, 6 A respectively 8 amps.

The booster is intended for indoor use only. When using outdoors appropriate protective measures (housings) are necessary.

CONNECTION

The booster should be attached to a standard model railroad transformer, which supplies 15 to 18 VAC. For smaller gauges like Z or N a secondary voltage of 12-15 VAC is recommended. The connection to a DC power supply unit is not possible.

The transformer output is attached to the terminals marked ~ (yellow and brown). Use wire with a sufficient cross section (at least $0,75\text{mm}^2$, AWG 18). The terminals permit cross sections up to $2,5\text{mm}^2$.

The tracks are attached to terminals 0 (ground, brown) and B (traction current, red), whereby the middle two terminals ~ and 0 carry ground level. Use sufficient cross section for wiring the tracks. We recommend at least 1.0mm^2 for H0. Pay attention to use sufficient supply points to the tracks. As a rule of thumb it's considered all 2 m a connection.

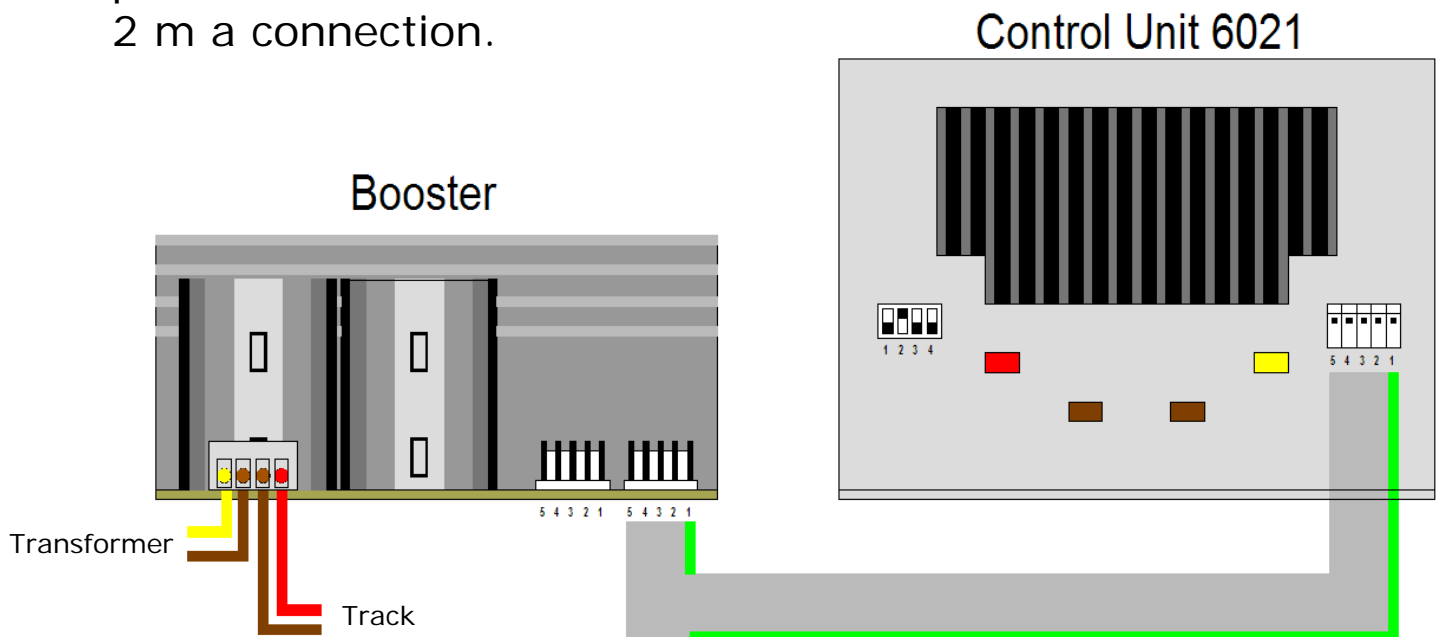

The booster communicates with the centre over the 5-pin flat cable, which is wired 1:1.

INSTALLATION

The booster is supplied as an open module. The installation into a housing is principally possible, however, sufficient circulation of air must be provided. A typical application is the hanging mounting underneath the railway plate. Make sure however in each case that the booster doesn't come into contact with any metallic or otherwise conducting materials or any metal parts can fall unintentionally on the electronics.

CONNECTION OF FURTHER BOOSTERS

Almost as many boosters as desired can be interconnected. Additional boosters are connected with the interface cable to the second plug of the previous booster (daisy chain). Each booster uses its own transformer.

FUNCTIONS

The boosters possess an automatic short circuit protection, which limits maximum output current. A short-circuit on the plant is announced over the interface cable to the central station, which then switches to stop. As soon as the short-circuit is removed, the "Go" key can be operated at the central unit, and the booster will continue to supply current to the tracks. A separate resetting of the boosters is thus not necessary nor available.

A power supply for interface converters is provided on pin 3 of the interface connectors. To activate this output, the jumper JP1 has to be placed (shorted).

The booster comes with three light emitting diodes (LED) for indicating the status:

Green LEDs Both on when the booster is attached correctly to the power supply. By using capacitors with high capacity the LEDs may glow a while after the power has been switched off.

Red LED On, if the central unit is on "start" (go). Using the booster directly with a PC (connecting the COM interface to the booster) the red LED flickers during data communication.
An appropriate cable for this type of connection can be found under part number 8009 in our shop (<http://Luessi.ch>).

USING THE BOOSTER WITH AN INTELLIBOX OR TWINCENTER

If you want to operate the Intellibox with attached booster in the DCC mode, you will need to set the special option 901 to 3, otherwise by the booster will cause a short circuit message. This is not a characteristic of the boosters presented here, but must also be set with other boosters (e.g. the Märklin 6015 and 6017).

GROUND

The ground connections of all transformers and all boosters can be interconnected. At the booster side this is already carried out on the printed circuit (the 2 middle terminals).

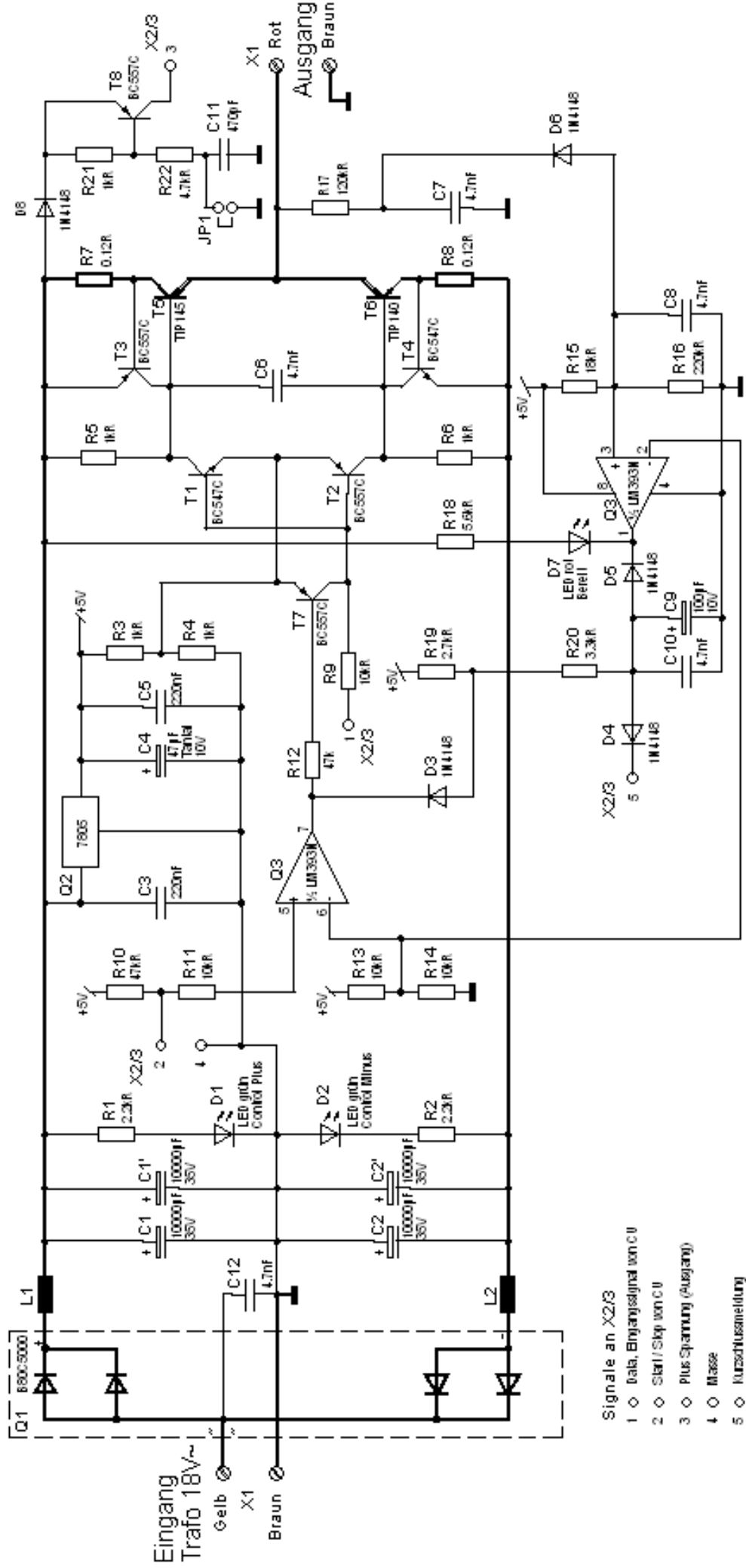

Signale an X2/3

- 1 ◊ Data, Eingangssignal von C11
- 2 ◊ Start/Skip von C11
- 3 ◊ Plus Spannung (Ausgang)
- 4 ◊ Masse
- 5 ◊ Kurzschlussleitung

Eingang
Trafo 18V~
Gelb X1
Braun

Ausgang
Rot
Braun

LAYOUT

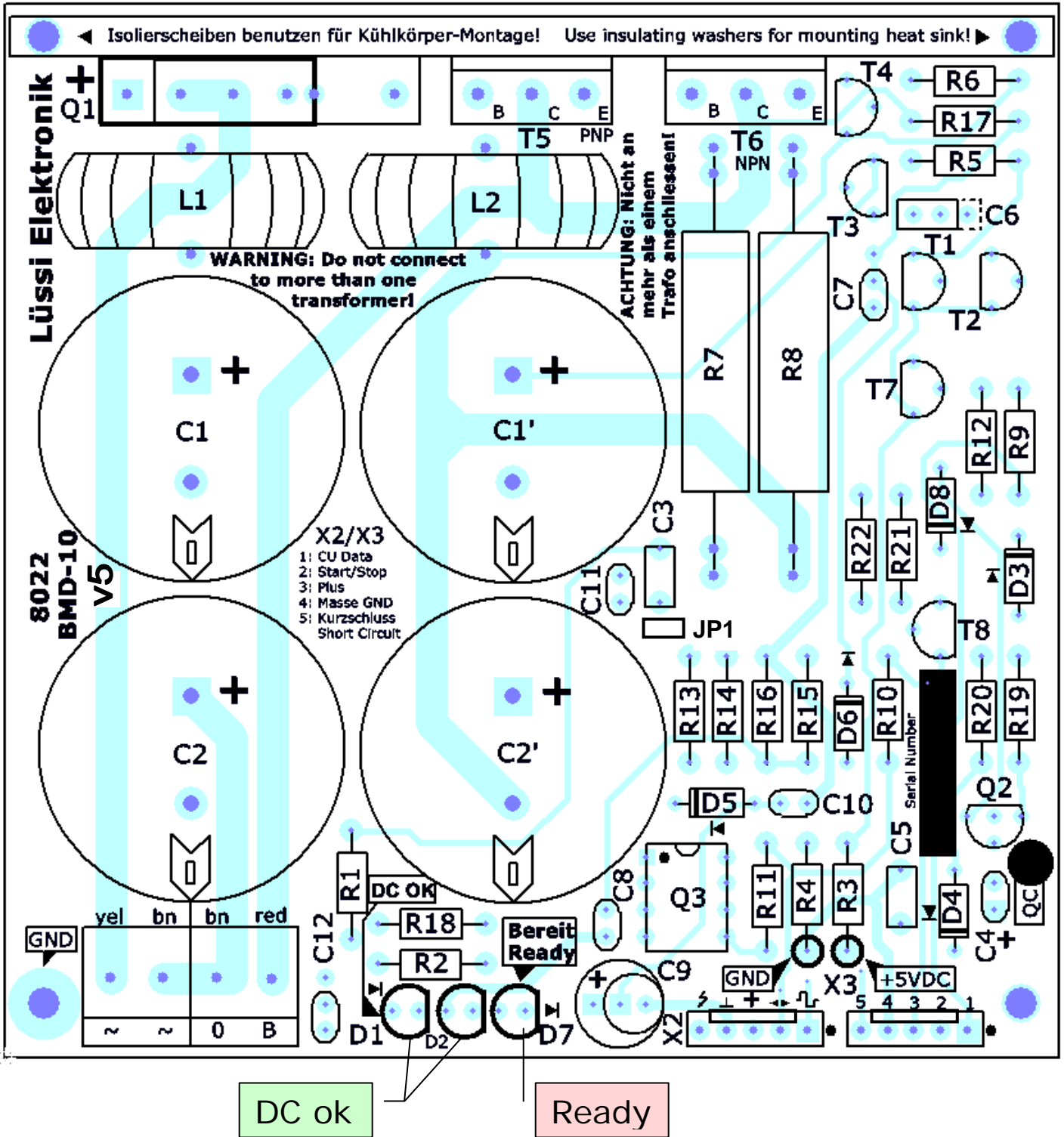

PARTS LIST

Symbol	Designation	Value	Symbol	Designation	Value
C1	Electrolyte capacitor	10'000µF, 35V	R1	Metallic film resistor 1%	2.2kΩ
C1' *1	Electrolyte capacitor	10'000µF, 35V	R2	Metallic film resistor 1%	2.2kΩ
C2	Electrolyte capacitor	10'000µF, 35V	R3	Metallic film resistor 1%	1kΩ
C2' *1	Electrolyte capacitor	10'000µF, 35V	R4	Metallic film resistor 1%	1kΩ
C3	Foil capacitor	220nF	R5	Metallic film resistor 1%	1kΩ
C4	Tantalum capacitor	10µF, 10V	R6	Metallic film resistor 1%	1kΩ
C5	Foil capacitor	220nF	R7	Wire resistor 5Watt 5%	0.15 / 0.10Ω *2
C6	Ceramic capacitor	47nF	R8	Wire resistor 5Watt 5%	0.15 / 0.10Ω *2
C7	Ceramic capacitor	4.7nF	R9	Metallic film resistor 1%	10kΩ
C8	Ceramic capacitor	4.7nF	R10	Metallic film resistor 1%	47kΩ
C9	Electrolyte capacitor	100µF, 10V	R11	Metallic film resistor 1%	10kΩ
C10	Ceramic capacitor	4.7nF	R12	Metallic film resistor 1%	47kΩ
C11	Ceramic capacitor	470pF	R13	Metallic film resistor 1%	10kΩ
C12	Ceramic capacitor	4.7nF	R14	Metallic film resistor 1%	10kΩ
D1	LED 3mm green	Control Plus	R15	Metallic film resistor 1%	18kΩ
D2	LED 3mm green	Control Minus	R16	Metallic film resistor 1%	220kΩ
D3	Silicon diode	1N4148	R17	Metallic film resistor 1%	120kΩ
D4	Silicon diode	1N4148	R18	Metallic film resistor 1%	5.6kΩ
D5	Silicon diode	1N4148	R19	Metallic film resistor 1%	2.7kΩ
D6	Silicon diode	1N4148	R20	Metallic film resistor 1%	3.3kΩ
D7	LED 3mm red	Ready	R21	Metallic film resistor 1%	1kΩ
D8	Silicon diode	1N4148	R22	Metallic film resistor 1%	4.7kΩ
L1	Choke coil	6A resp. 8A	T1	Transistor NPN	BC547C
L2	Choke coil	6A resp. 8A	T2	Transistor PNP	BC557C
Q1	Bridge rectifier	B40C5500 *3 KBU 8G	T3	Transistor PNP	BC557C
Q2	Voltage regulator 5V	78L05	T4	Transistor NPN	BC547C
Q3	Comparator	LM393N	T5	Darlington power transistor PNP	TIP145/147 *3 BDW84B
			T6	Darlington power transistor NPN	TIP140/142 *3 BDW83B
			T7	Transistor PNP	BC557C
			T8	Transistor PNP	BC557C

*1 For the 6 A and 8 A version only.

*2 For the 4 A Version: 0.15 Ω, 6 A version: 0.10 Ω, 8 A version: 2 x 0.15 Ω in parallel each (one above the other).

*3 Only possible for the 4 A and 6 A version.

TECHNICAL DATA

	4A version	6A version	8A version
Max. output current	4 A	6 A	8 A
Transformer power	72 VA	108 VA	150 VA
Input voltage	12–20 VAC	12-20 VAC	12-20 VAC
Protection class	IP00 (open)	IP00 (open)	IP00 (open)
Size (mm) approx.	100x107x40	100x116x50	100x120x58

FURTHER INFORMATION

You will find further information on the homepage
<http://www.stayathome.ch>

CONTACT

Lüssi Hobbyartikel, Russikerstrasse 77, CH-8320
Fehraltorf, Switzerland
Tel: +41 44 995 6600, Fax: +41 44 995 6604
E-Mail: booster@luessi.ch

* Note: "Märklin", "Motorola" and other names used in this document are registered trademarks of the respective companies.